

CS062

DATA STRUCTURES AND ADVANCED PROGRAMMING

20-21: Hash tables



Alexandra Papoutsaki

Lecture 20-21: Hash tables

- ▶ Hash functions
- ▶ Separate chaining
- ▶ Open addressing

Basic plan for implementing dictionaries using hashing

- ▶ **Goal:** Build a key-indexed array (table or hash table or hash map) to model dictionaries for efficient ($O(1)$) search.
- ▶ **Hash function:** Method to transform key into an array index
 - ▶ Also known as the **hash value**.
 - ▶ $\text{hash}(\text{"California"}) = 2$
 - ▶ $\text{hash}(\text{"Texas"}) = 2 \text{ ???}$
- ▶ **Issues:**
 - ▶ Computing the hash function.
 - ▶ Method for checking whether two keys are equal.
 - ▶ How to handle **collisions** when two keys hash to same index.

0	
1	
2	(California, 39.24)
3	
4	

Computing hash function

- ▶ **Ideal scenario:** Take any key and uniformly “scramble” it to produce a table/dictionary index.
- ▶ **Requirements:**
 - ▶ Consistent - equal keys must produce the same hash value.
 - ▶ Efficient - quick computation of hash value.
 - ▶ Uniform distribution - every index is equally likely for each key.
- ▶ Although thoroughly researched, still problematic in practical applications.
- ▶ **Examples:** Dictionary where keys are social security numbers.
 - ▶ Bad: if we choose the first three digits (geographical region and time).
 - ▶ Better: if we choose the last three digits.
 - ▶ Best: use all data.
- ▶ **Practical challenge:** Need different approach for each key type.

Hashing in Java

- ▶ All Java classes inherit a method `hashCode()`, which returns an integer.
- ▶ **Requirement:** If `x.equals(y)` then it should be `x.hashCode()==y.hashCode()`.
- ▶ **Ideally (but not necessarily):** If `!x.equals(y)` then it should be `x.hashCode()!=y.hashCode()`.
- ▶ **Default implementation:** Memory address of `x`.
 - ▶ Need to override *both* `equals()` and `hashCode()` for custom types.
 - ▶ Already done for us for `Integer`, `Double`, etc.

Equality test in Java

- ▶ **Requirement:** For any objects x , y , and z .
 - ▶ **Reflexive:** $x.equals(x)$ is true.
 - ▶ **Symmetric:** $x.equals(y)$ iff $y.equals(x)$.
 - ▶ **Transitive:** if $x.equals(y)$ and $y.equals(z)$ then $x.equals(z)$.
 - ▶ **Non-null:** if $x.equals(\text{null})$ is false.
- ▶ If you don't override it, the default implementation checks whether x and y refer to the same object in memory.

Java implementations of equals() for user-defined types

```
▶ public class Date {  
    private int month;  
    private int day;  
    private int year;  
  
    ...  
    public boolean equals(Object y) {  
        if (y == this) return true;  
        if (y == null) return false;  
        if (y.getClass() != this.getClass()) return false;  
        Date that = (Date) y;  
        return (this.day == that.day &&  
                this.month == that.month &&  
                this.year == that.year);  
    }  
}
```

General equality test recipe in Java: `x.equals(y)`

- ▶ Optimization for reference equality.
 - ▶ `if (y == this) return true;`
- ▶ Check against `null`.
 - ▶ `if (y == null) return false;`
- ▶ Check that two objects are of the same type.
 - ▶ `if (y.getClass() != this.getClass()) return false;`
- ▶ Cast them.
 - ▶ `Date that = (Date) y;`
- ▶ Compare each significant field (i.e. instance variable).
 - ▶ `return (this.day == that.day && this.month == that.month && this.year == that.year);`
 - ▶ If a field is a primitive type, use `==`.
 - ▶ If a field is an object, use `equals()`.
 - ▶ If field is an array of primitives, use `Arrays.equals()`.
 - ▶ If field is an array of objects, use `Arrays.deepEquals()`.

Java implementations of hashCode()

- ▶

```
public final class Integer {  
    private final int value;  
  
    ...  
    public int hashCode() {  
        return (value);  
    }  
}
```
- ▶

```
public final class Boolean {  
    private final boolean value;  
  
    ...  
    public int hashCode() {  
        if(value)    return 1231;  
        else return 1237;  
    }  
}
```

Java implementations of hashCode() for user-defined types

```
▶ public class Date {  
    private int month;  
    private int day;  
    private int year;  
    ...  
    public int hashCode() {  
        int hash = 1;  
        hash = 31*hash + ((Integer) month).hashCode();  
        hash = 31*hash + ((Integer) day).hashCode();  
        hash = 31*hash + ((Integer) year).hashCode();  
        return hash;  
        //could be also written as  
        //return Objects.hash(month, day, year);  
    }  
}
```

31x+y rule

General hash code recipe in Java

- ▶ Combine each significant field using the $31x+y$ rule.
- ▶ Shortcut 1: use `Objects.hash()` for all fields (except arrays).
- ▶ Shortcut 2: use `Arrays.hashCode()` for primitive arrays.
- ▶ Shortcut 3: use `Arrays.deepHashCode()` for object arrays.

Modular hashing

- ▶ **Hash code**: an `int` between -2^{31} and $2^{31} - 1$
- ▶ **Hash value**: an `int` between 0 and $m - 1$, where m is the hash table size (typically a prime number or power of 2).
- ▶ The class that implements the dictionary of size m should implement a hash function. Examples:
 - ▶ `private int hash (Key key){
 return key.hashCode() % m;
}`
 - ▶ Bug! Might map to negative number.
 - ▶ `private int hash (Key key){
 return Math.abs(key.hashCode()) % m;
}`
 - ▶ Very unlikely bug. For a hash code of -2^{31} , `Math.abs` will return a negative number!
 - ▶ `private int hash (Key key){
 return (key.hashCode() & 0x7fffffff) % m;
}`
 - ▶ Correct.

Uniform hashing assumption

- ▶ **Uniform hashing assumption:** Each key is equally likely to hash to an integer between 0 and $m - 1$.
- ▶ **Mathematical model:** balls & bins. Toss n balls uniformly at random into m bins.
- ▶ **Bad news:** Expect two balls in the same bin after $\sim\sqrt{(\pi m/2)}$ tosses.
 - ▶ **Birthday problem:** In a random group of 23 or more people, more likely than not that two people will share the same birthday.
- ▶ **Good news: load balancing**
 - ▶ When $n \gg m$, the number of balls in each bin is “likely close” to n/m .

Lecture 20-21: Hash tables

- ▶ Hash functions
- ▶ Separate chaining
- ▶ Open addressing

Separate/External Chaining (Closed Addressing)

- ▶ Use an array of $m < n$ distinct linked lists (chains) [H.P. Luhn, IBM 1953].
 - ▶ **Hash:** Map key to integer i between 0 and $m - 1$.
 - ▶ **Insert:** Put key-value pair at front of i -th chain (if not already there in which case we only update the associated value).
 - ▶ **Search:** Need to only search the i -th chain.

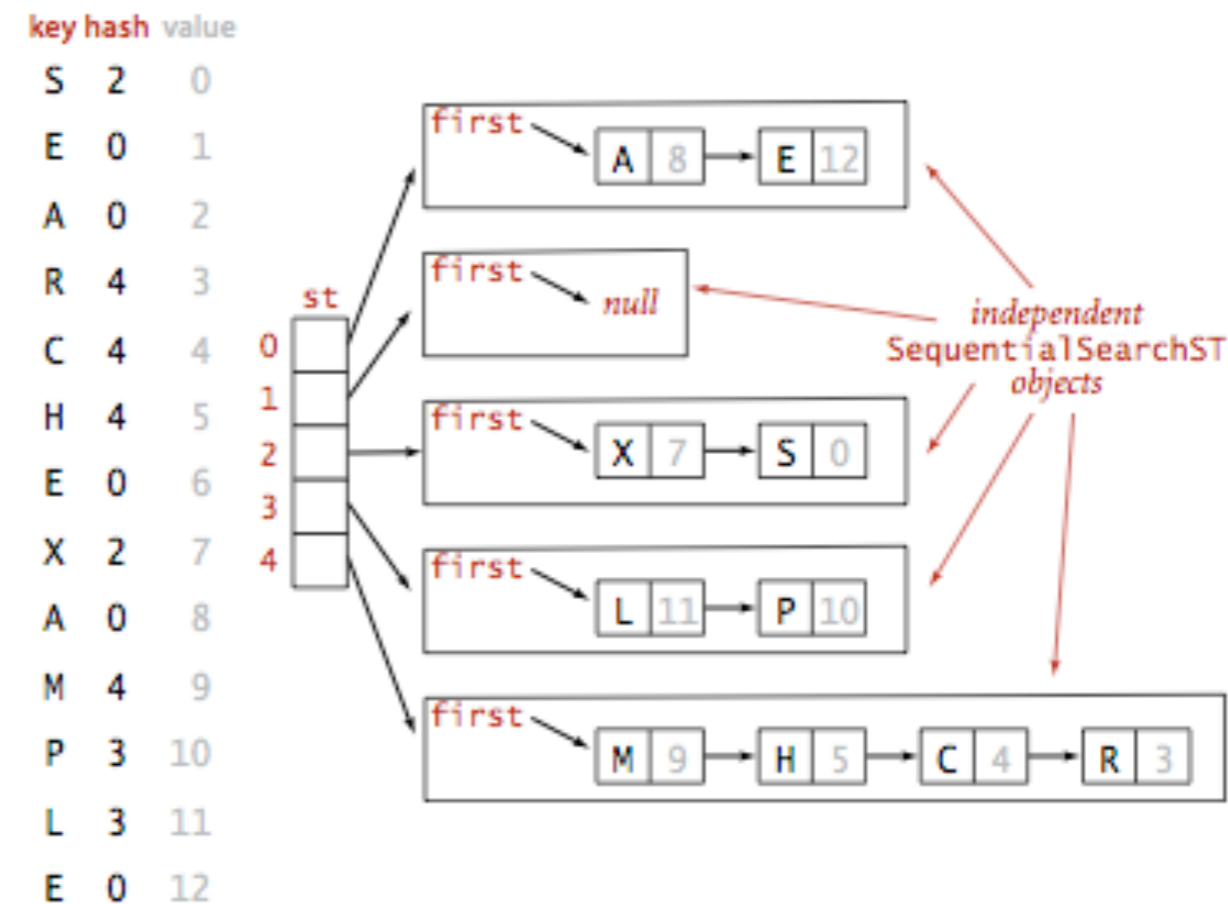

Hashing with separate chaining for standard indexing client

Separate Chaining Example

- ▶ Let's assume we implement a dictionary using hashing and separate chaining for collisions.
- ▶ The size of the table is 5, that is $m = 5$.
- ▶ We will hash the keys S, E, A, R, C, H, E, X, A, M, P, L, E where I will provide you with their hash values.
- ▶ Every time we hash a key, we go to the chain attached to that index and traverse the linked list.
 - ▶ If we find a node with the same key we want to insert, we just update its corresponding value.
 - ▶ If no node contains our key, we insert the key-value pair at the head of the chain.

Separate Chaining Example

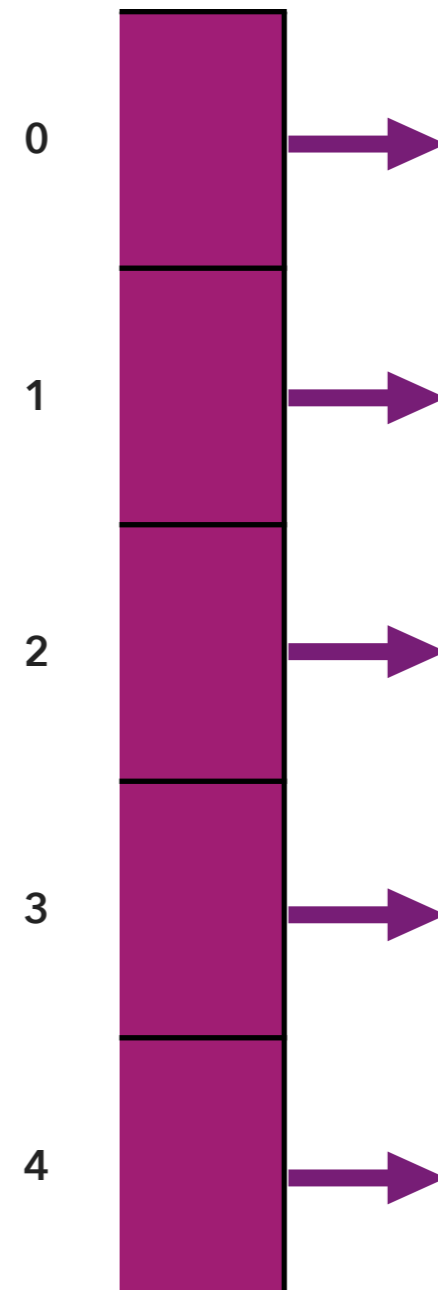

Next step: Insert (S, 0)

Separate Chaining Example

Key	Hash	Value
S	2	0

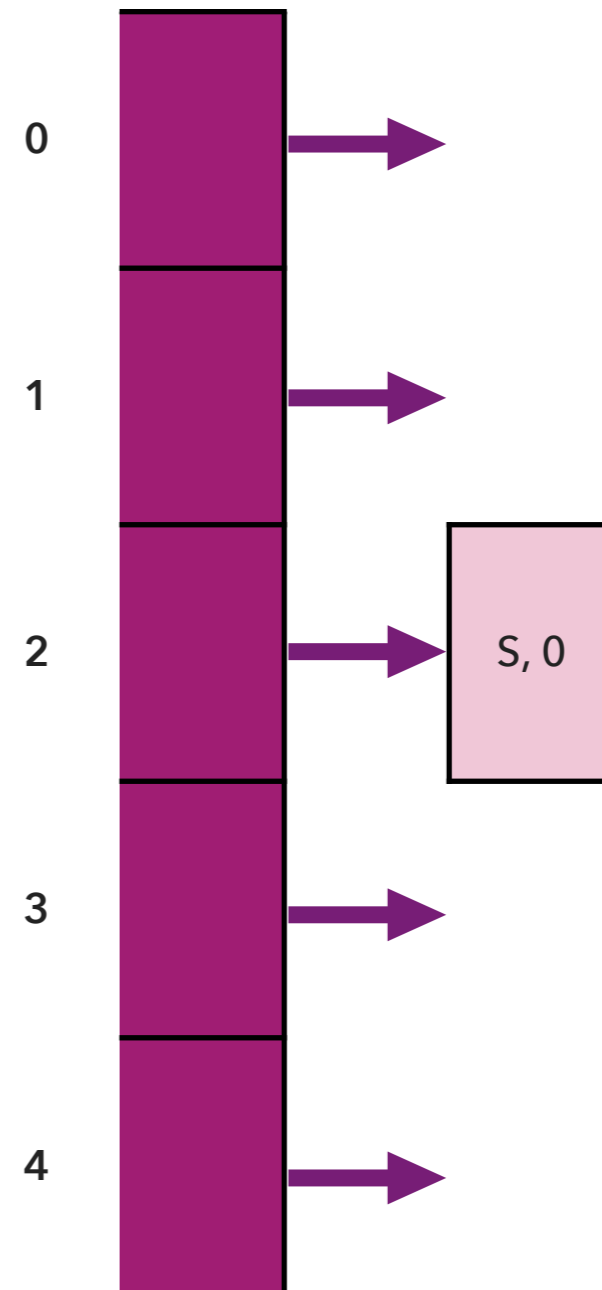

Next step: Insert (E, 1)

Separate Chaining Example

Key	Hash	Value
S	2	0
E	0	1

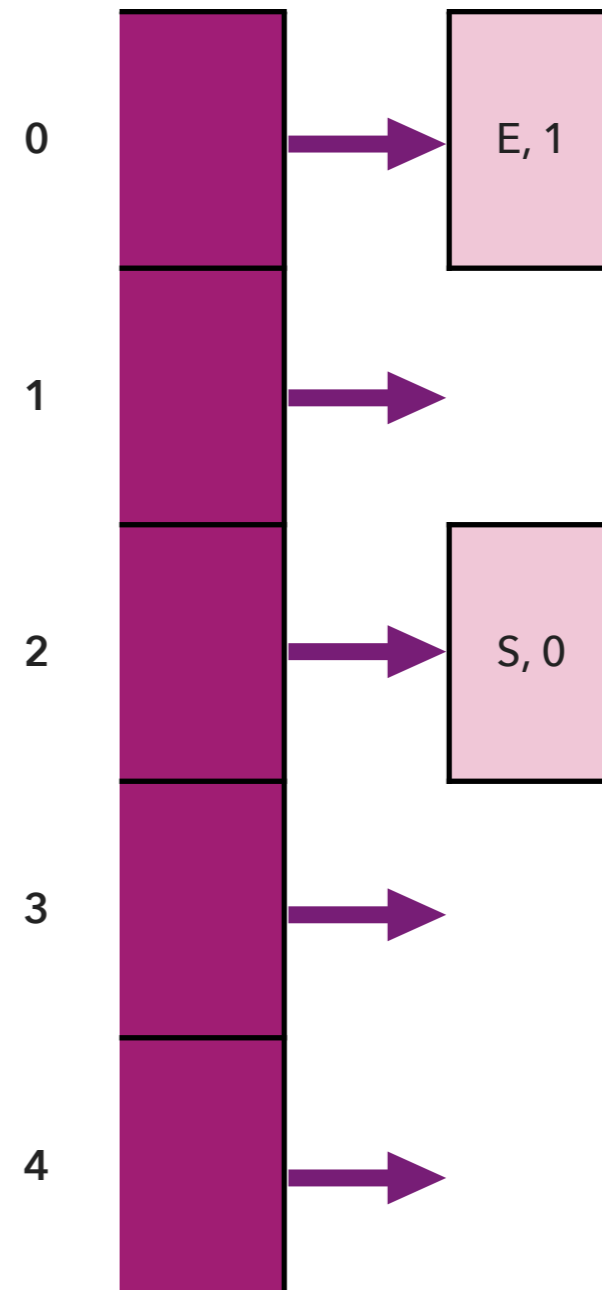

Next step: Insert (A, 2)

Separate Chaining Example

Key	Hash	Value
S	2	0
E	0	1
A	0	2

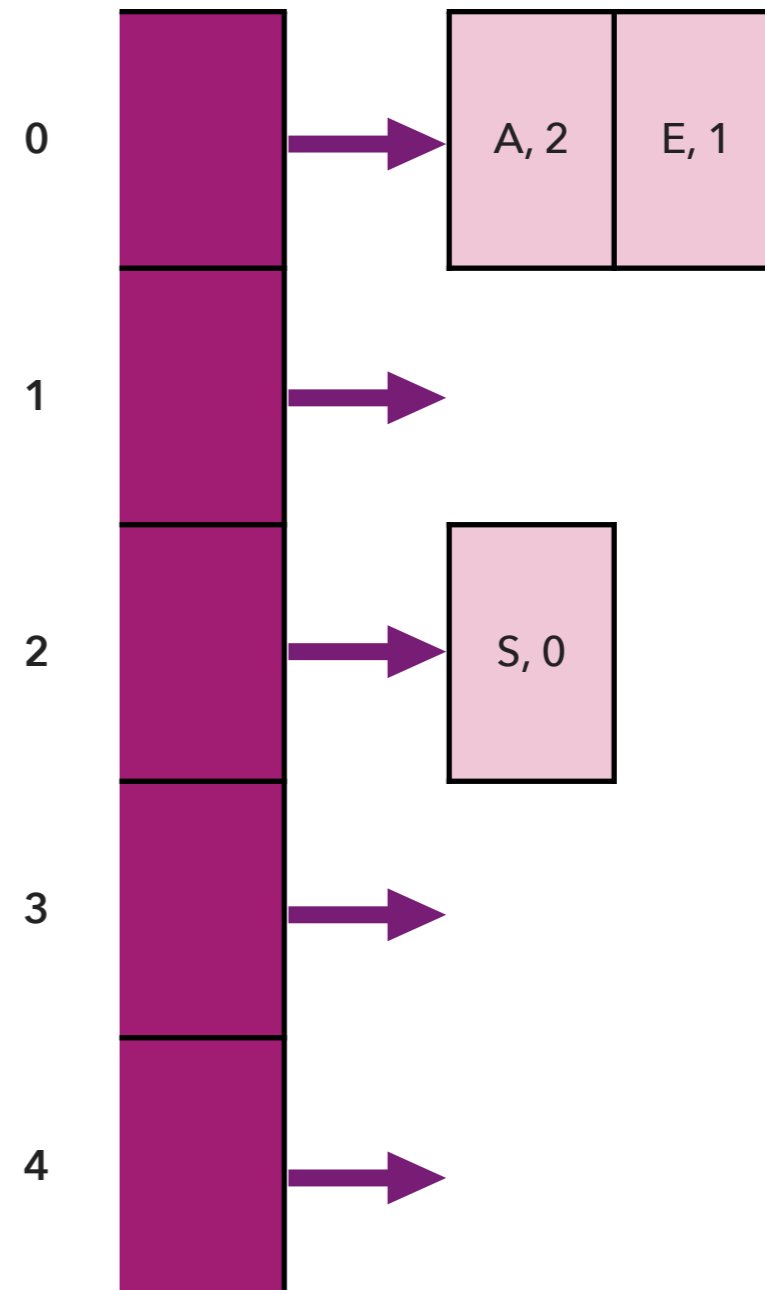

Next step: Insert (R, 3)

Separate Chaining Example

Key	Hash	Value
S	2	0
E	0	1
A	0	2
R	4	3

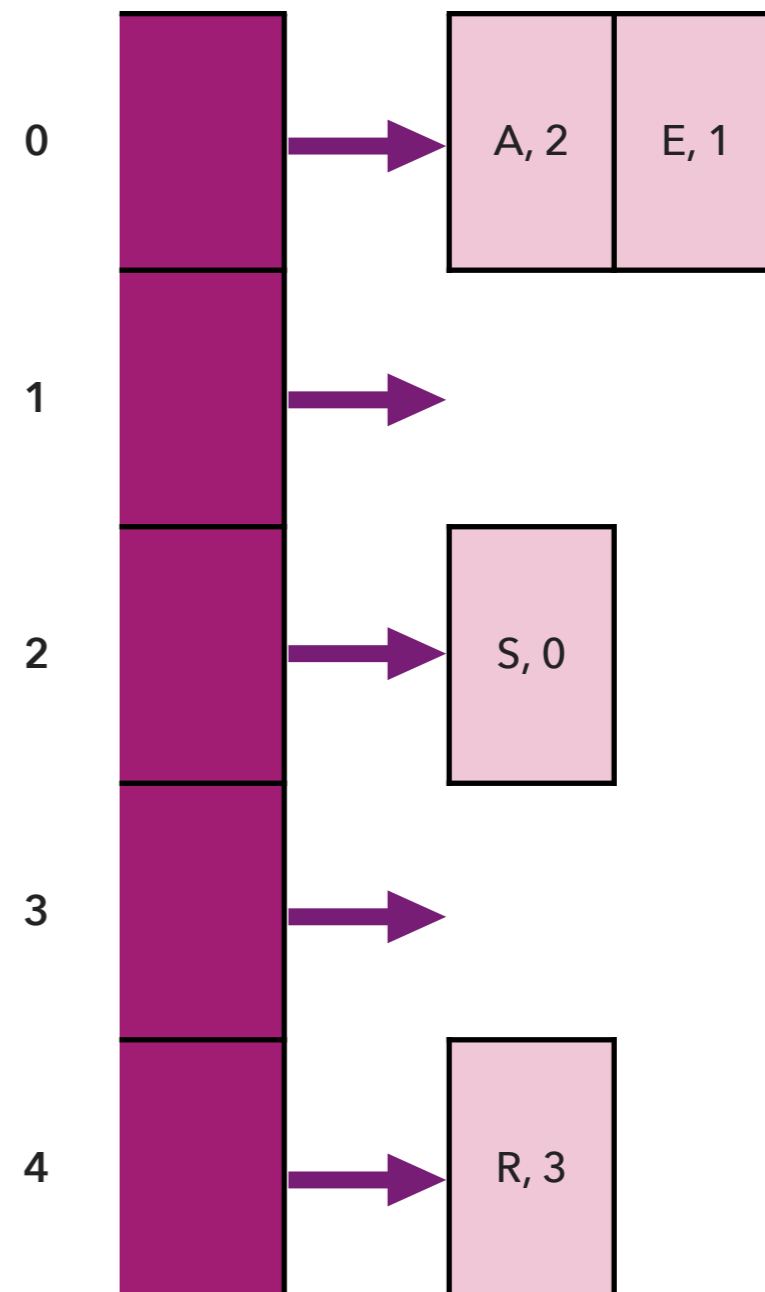

Next step: Insert (C, 4)

Separate Chaining Example

Key	Hash	Value
S	2	0
E	0	1
A	0	2
R	4	3
C	4	4

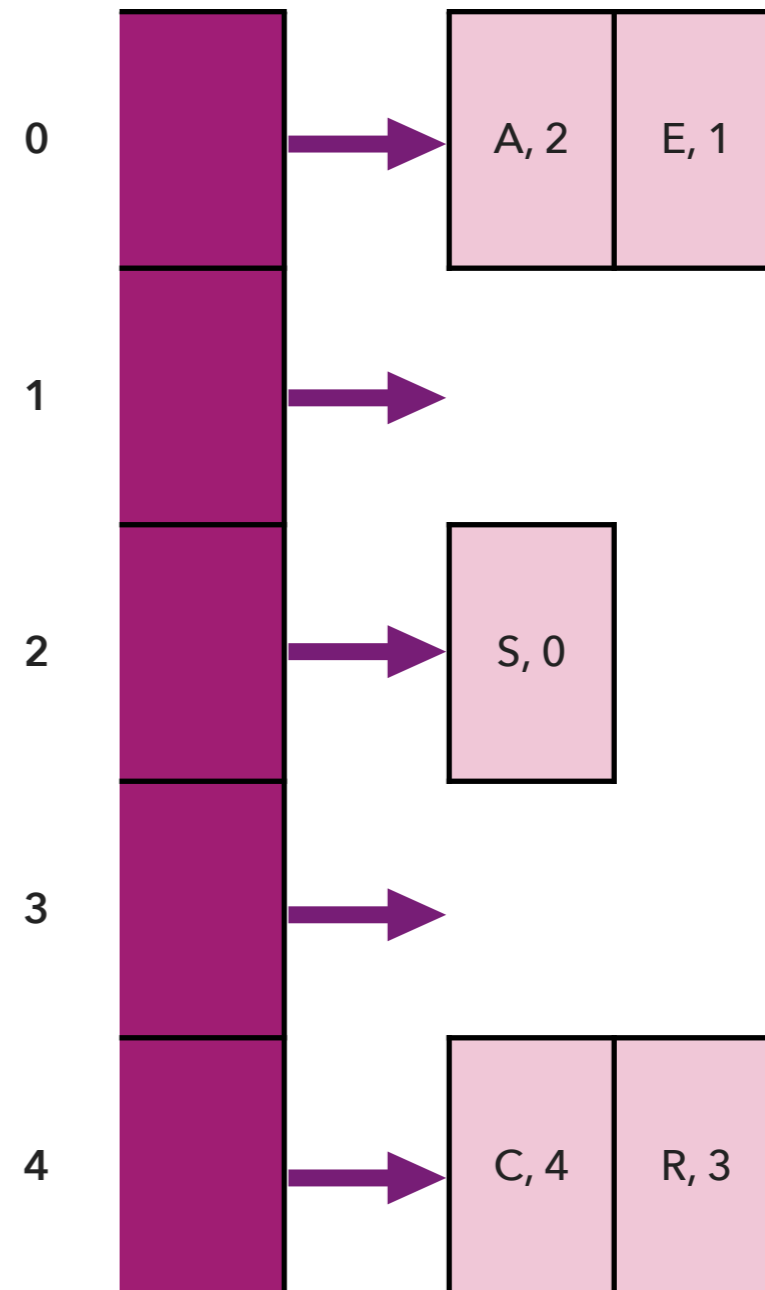

Next step: Insert (H, 5)

Separate Chaining Example

Key	Hash	Value
S	2	0
E	0	1
A	0	2
R	4	3
C	4	4
H	4	5

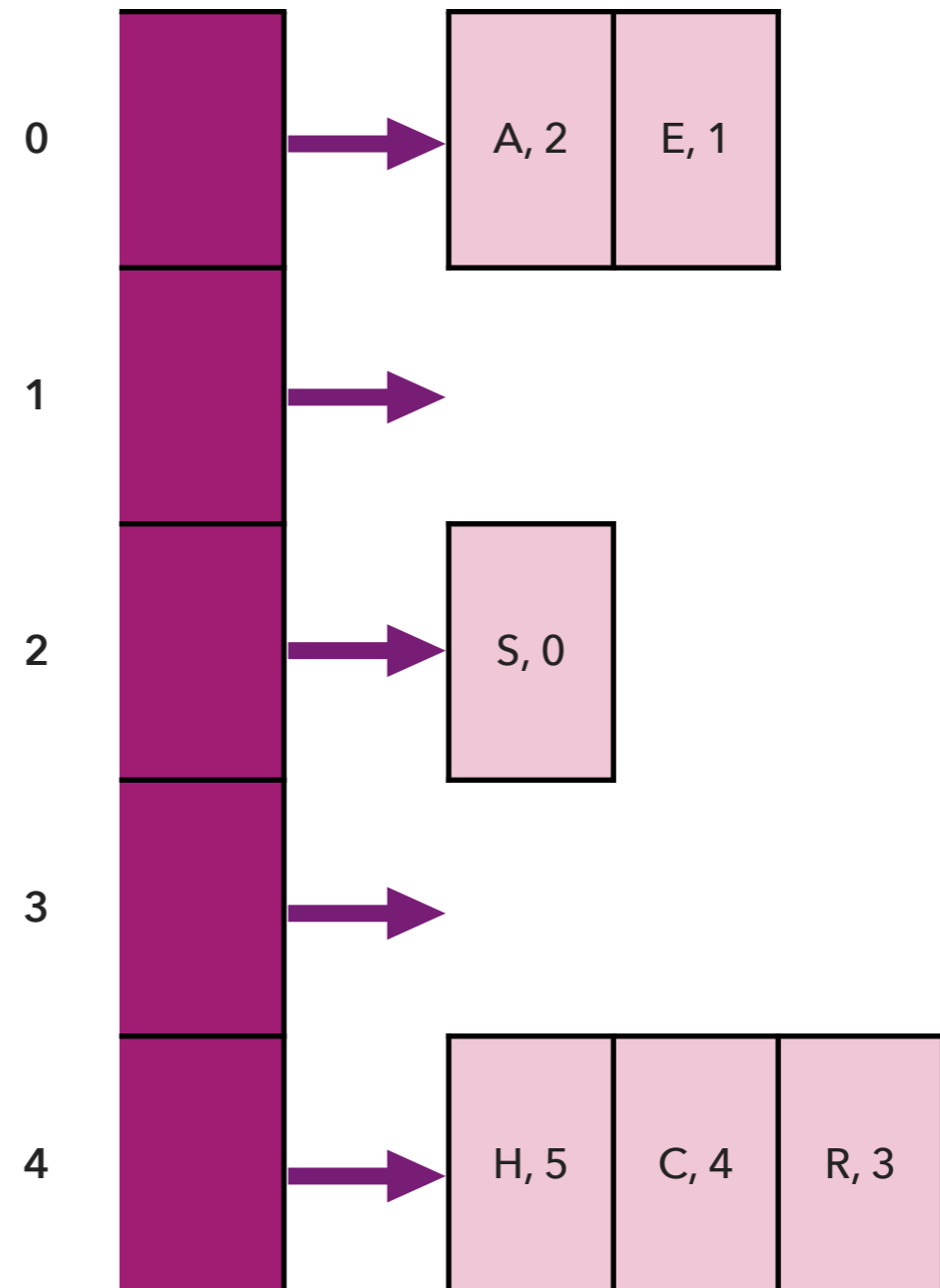

Next step: Insert (E, 6)

Separate Chaining Example

Key	Hash	Value
S	2	0
E	0	1
A	0	2
R	4	3
C	4	4
H	4	5
E	0	6

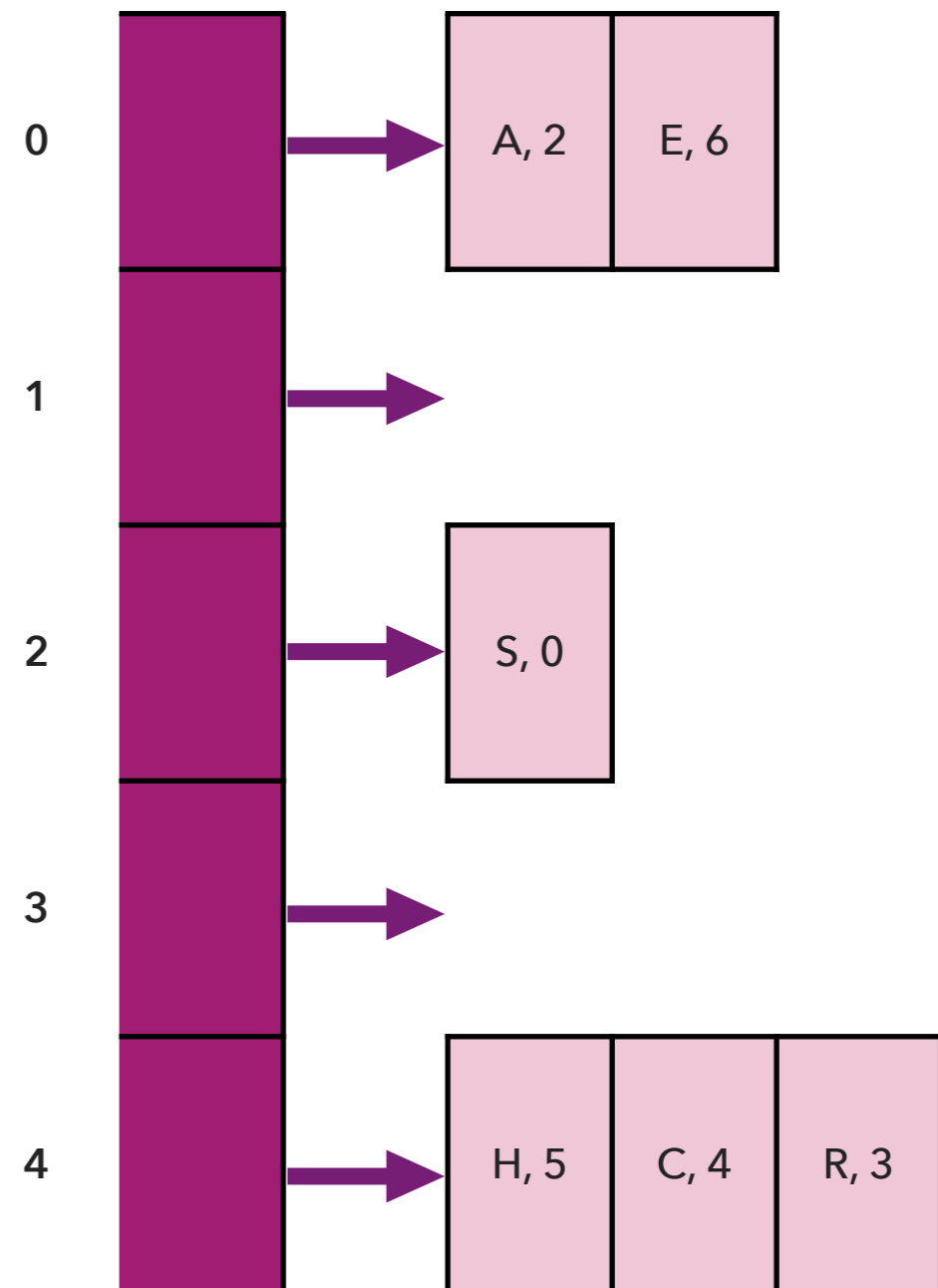

Next step: Insert (X, 7)

Separate Chaining Example

Key	Hash	Value
S	2	0
E	0	1
A	0	2
R	4	3
C	4	4
H	4	5
E	0	6
X	2	7

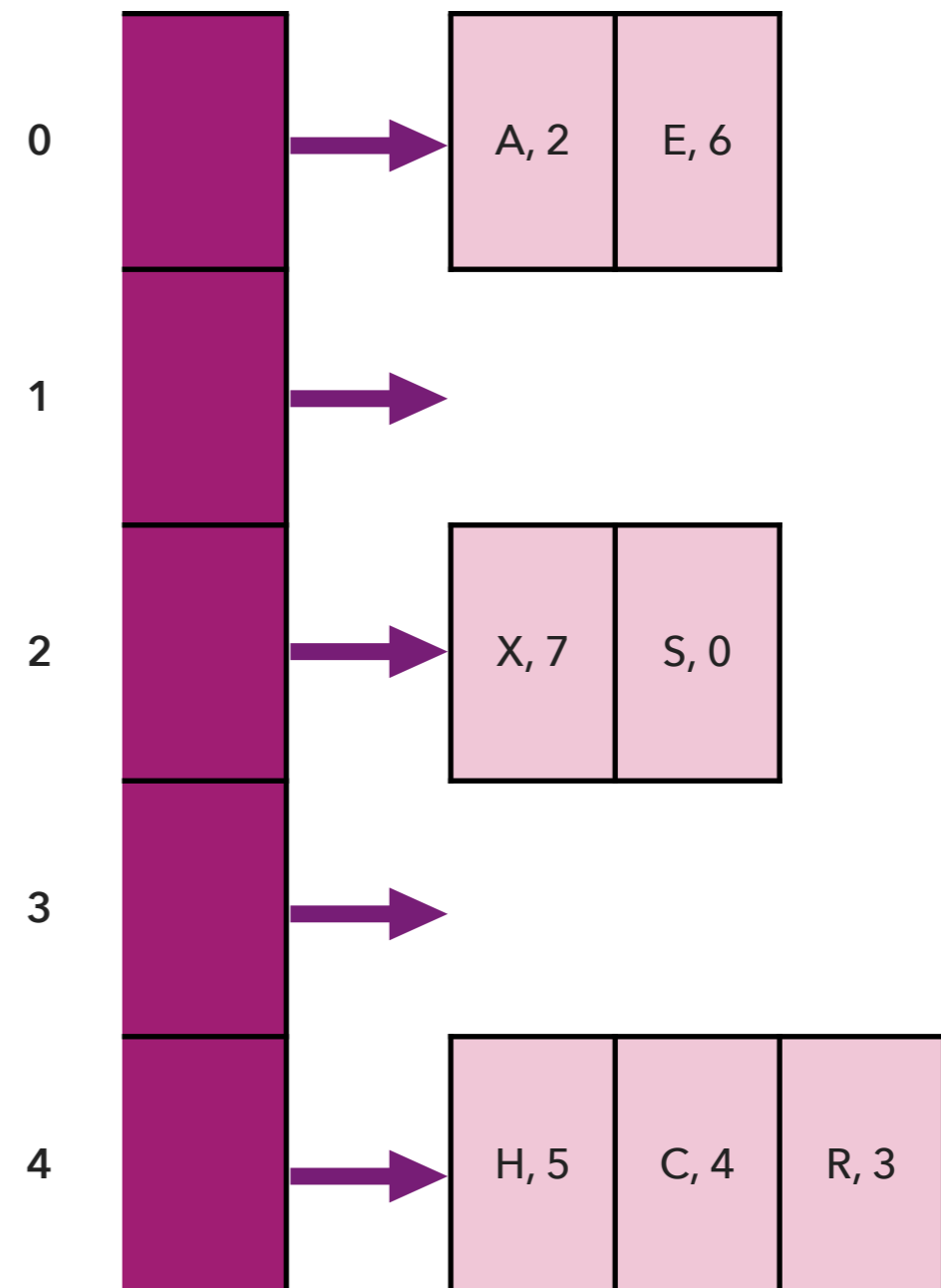

Next step: Insert (A, 8)

Separate Chaining Example

Key	Hash	Value
S	2	0
E	0	1
A	0	2
R	4	3
C	4	4
H	4	5
E	0	6
X	2	7
A	0	8

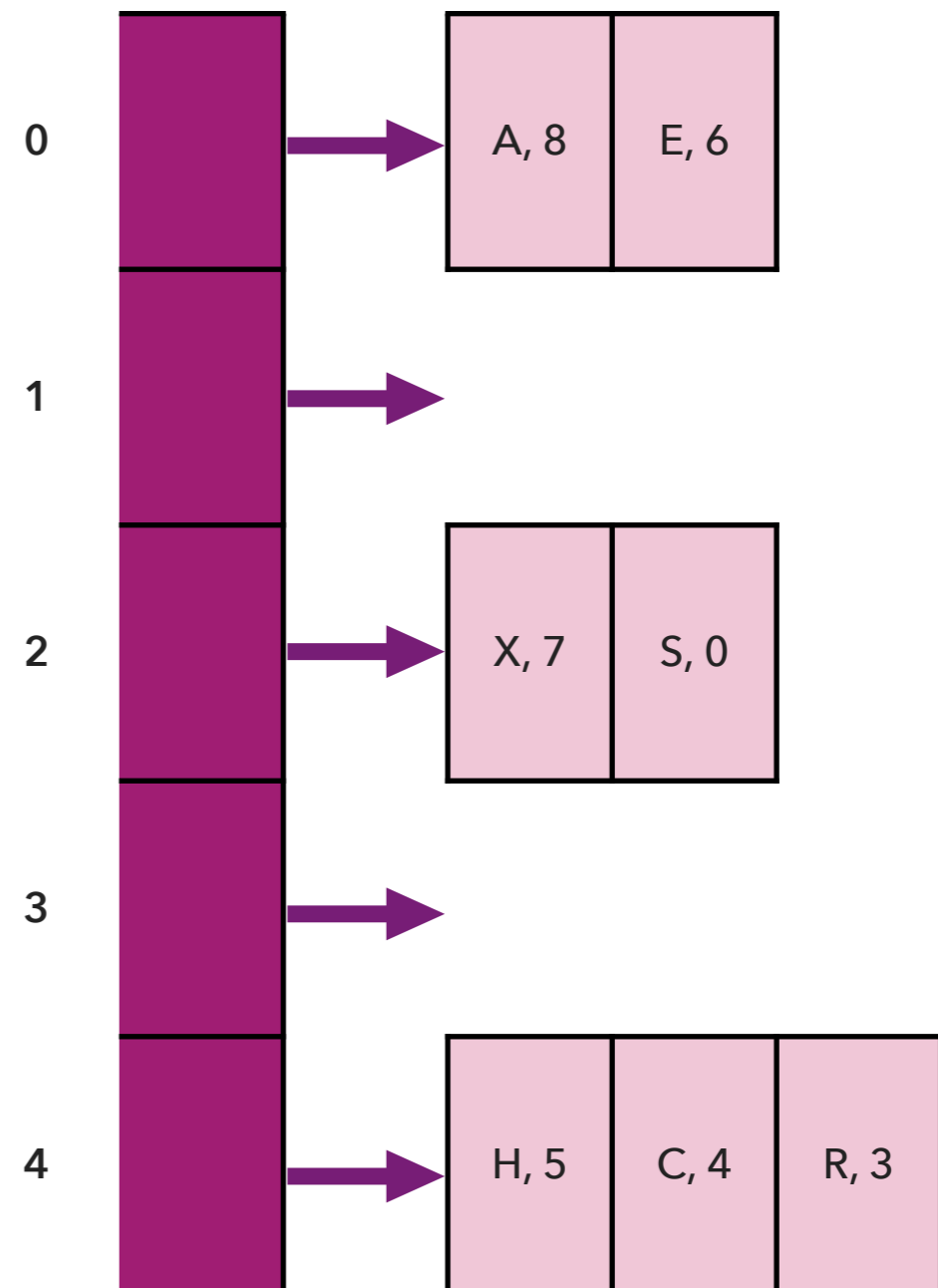

Next step: Insert (M, 9)

Separate Chaining Example

Key	Hash	Value
S	2	0
E	0	1
A	0	2
R	4	3
C	4	4
H	4	5
E	0	6
X	2	7
A	0	8
M	4	9

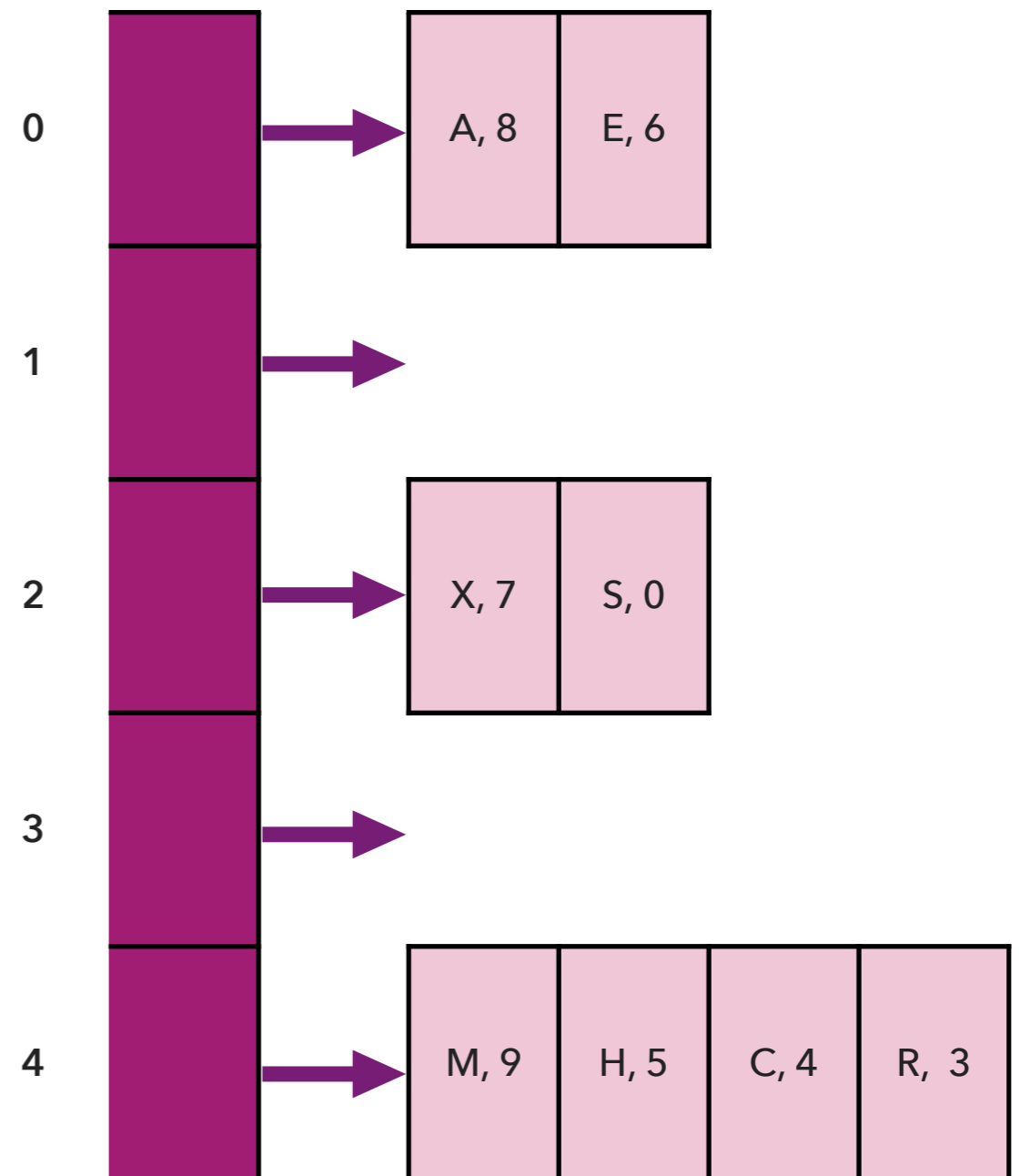

Next step: Insert (P, 10)

Separate Chaining Example

Key	Hash	Value
S	2	0
E	0	1
A	0	2
R	4	3
C	4	4
H	4	5
E	0	6
X	2	7
A	0	8
M	4	9
P	3	10

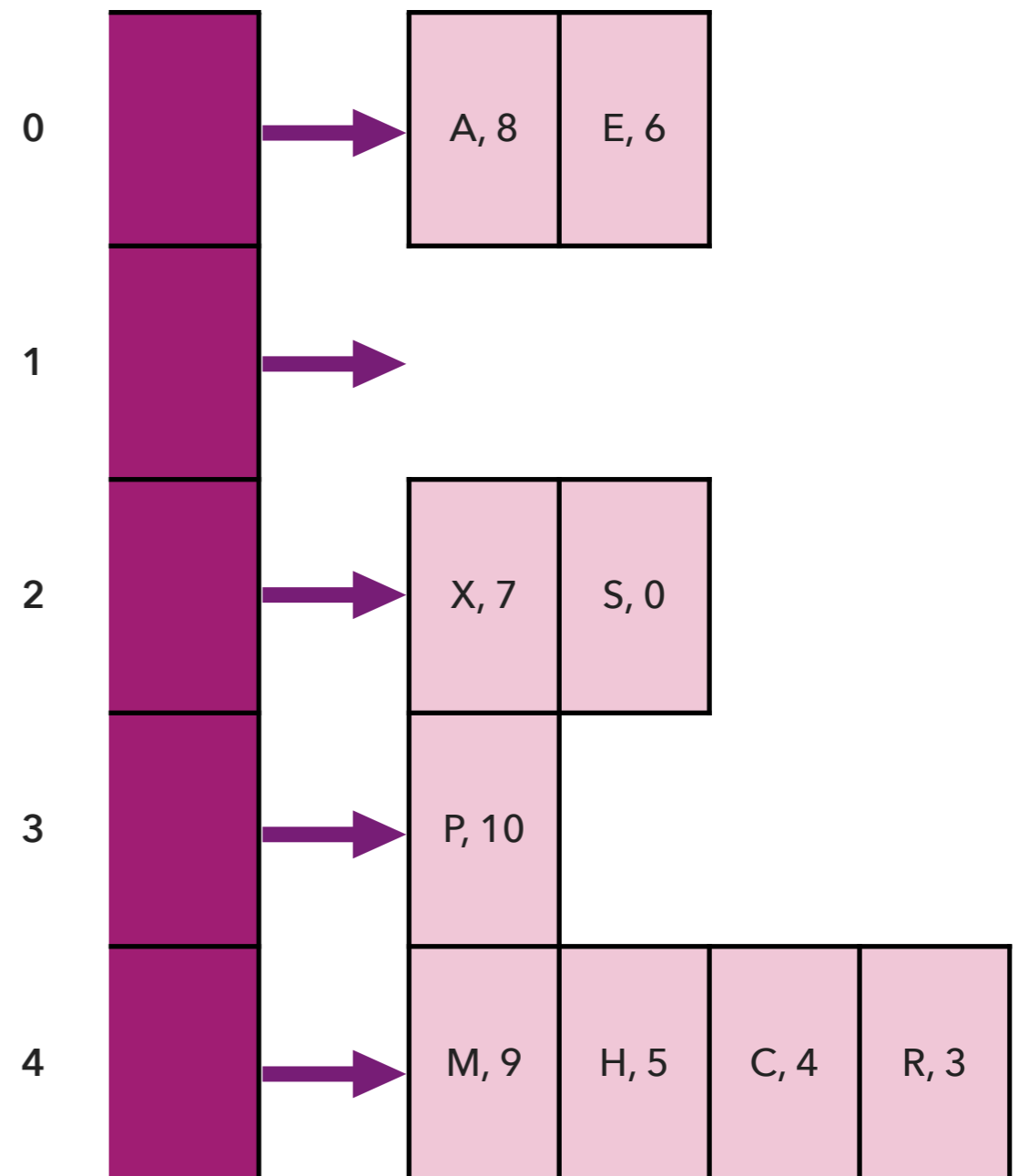

Next step: Insert (L, 11)

Separate Chaining Example

Key	Hash	Value
S	2	0
E	0	1
A	0	2
R	4	3
C	4	4
H	4	5
E	0	6
X	2	7
A	0	8
M	4	9
P	3	10
L	3	11

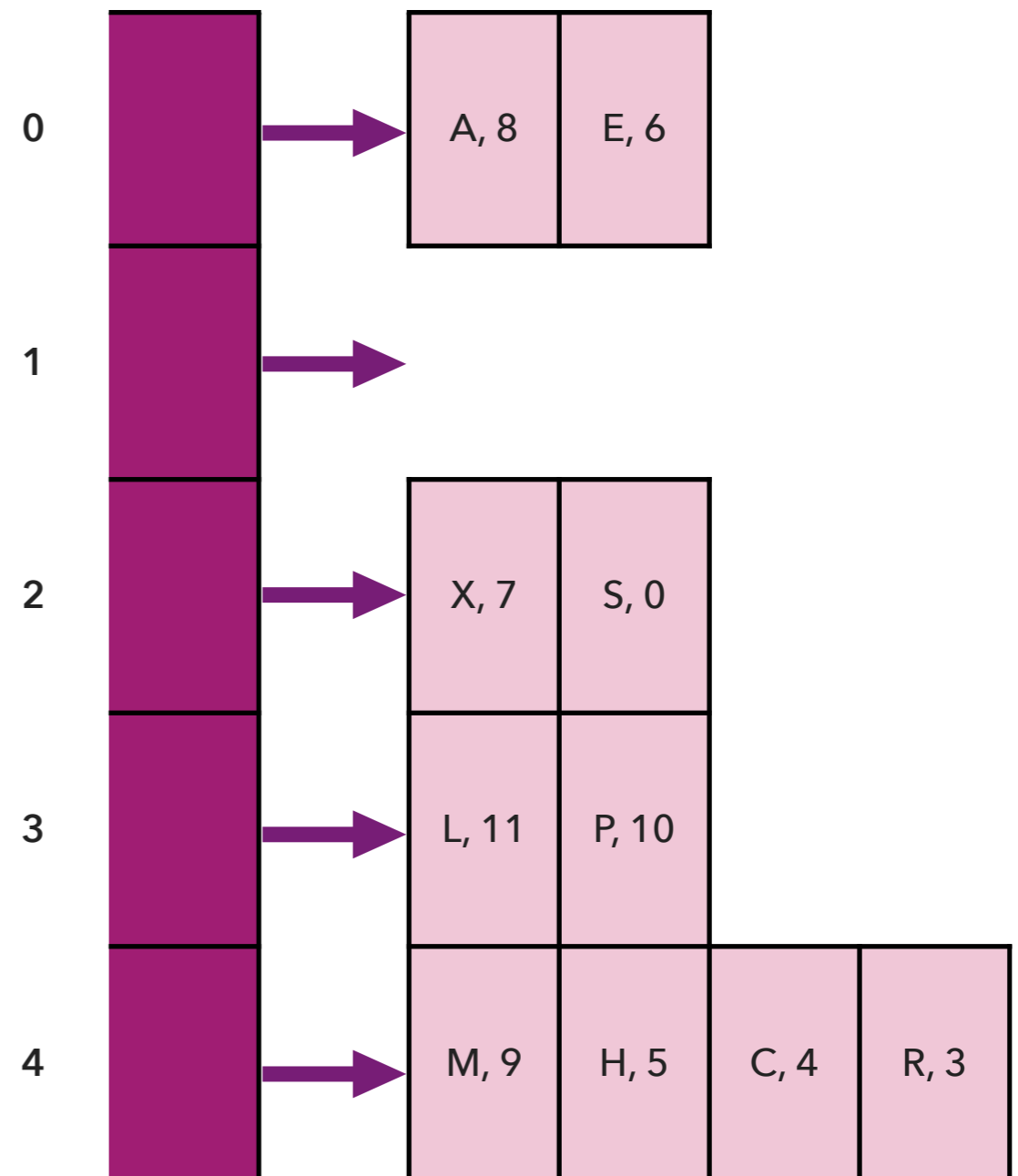

Next step: Insert (E, 12)

Separate Chaining Example

Key	Hash	Value
S	2	0
E	0	1
A	0	2
R	4	3
C	4	4
H	4	5
E	0	6
X	2	7
A	0	8
M	4	9
P	3	10
L	3	11
E	0	12

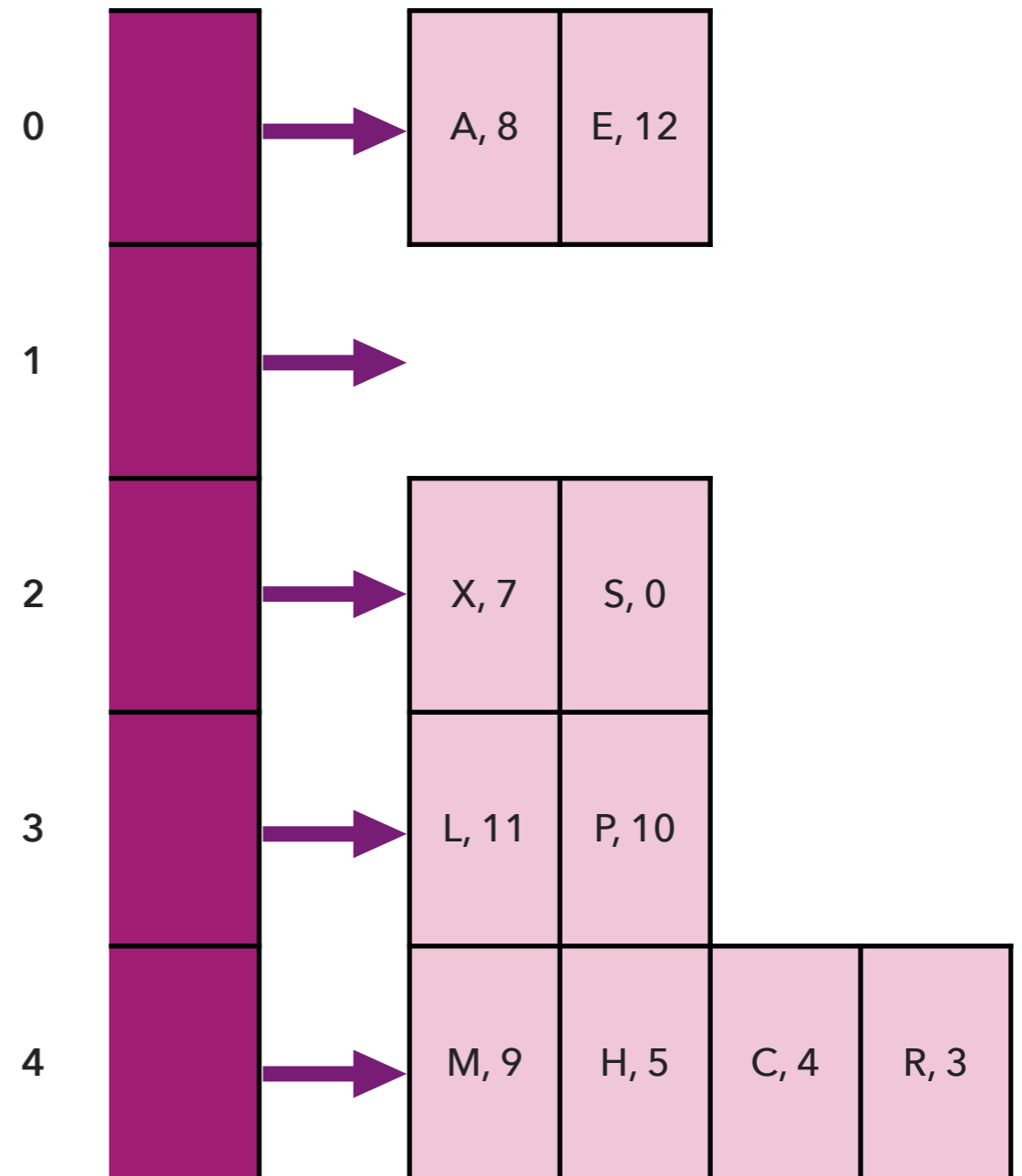

Practice Time

- ▶ Assume a dictionary implemented using hashing and separate chaining for handling collisions.
- ▶ Let $m = 7$ be the hash table size.
- ▶ For simplicity, we will assume that keys are integers and that the hash value for each key k is calculated as $h(k) = k \% m$.
- ▶ Insert the key-value pairs $(47, 0)$, $(3, 1)$, $(28, 2)$, $(14, 3)$, $(9, 4)$, $(47, 5)$ and show the resulting dictionary.

Answer

Key	Hash	Value
47	5	0
3	3	1
28	0	2
14	0	3
9	2	4
47	5	5

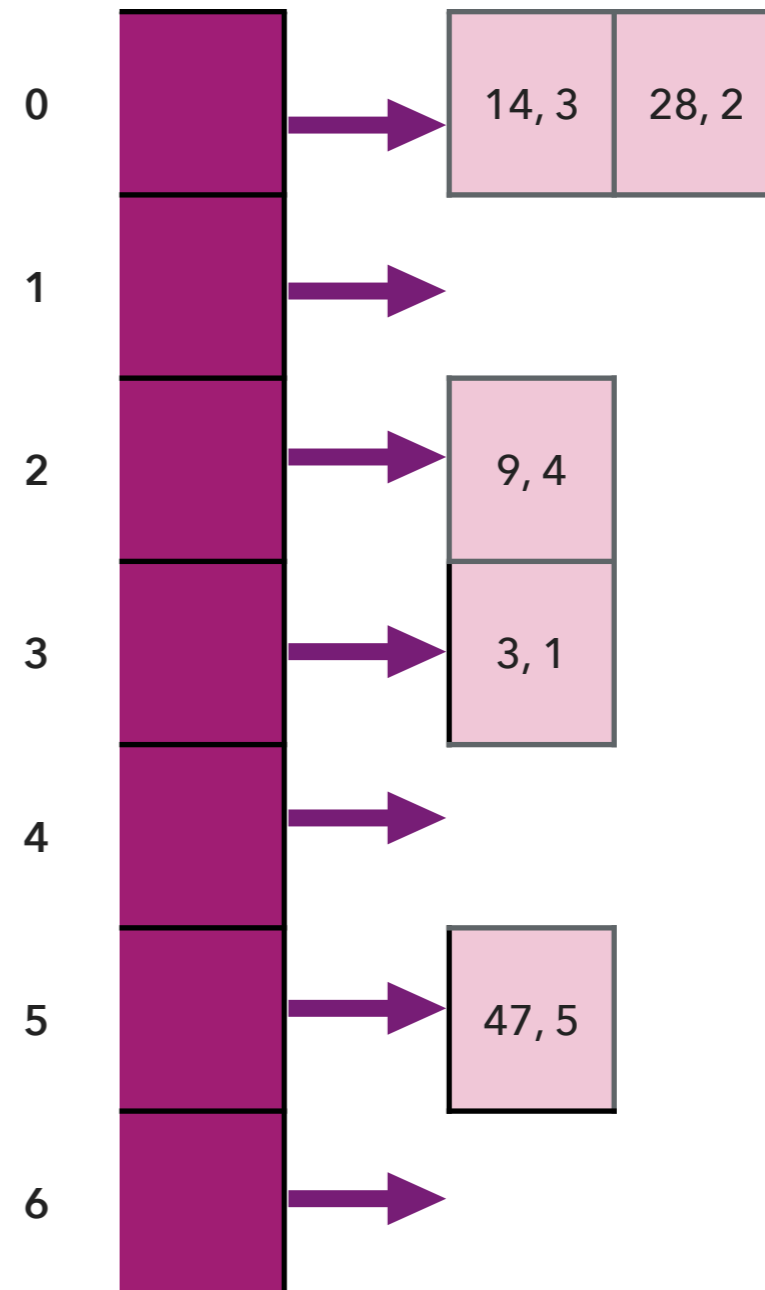

Dictionary with separate chaining implementation

```
public class SeparateChainingLiteHashST<Key, Value> {  
  
    private int m = 128; // hash table size  
    private Node[] st = new Node[m];  
    // array of linked-list dictionaries.  
    //Node is inner class that holds keys and values of type Object  
  
    public Value get(Key key) {  
        int i = hash(key);  
        for (Node x = st[i]; x != null; x = x.next;)  
            if (key.equals(x.key)) return (Value) x.val;  
        return null;  
    }  
  
    public void put(Key key, Value val) {  
        int i = hash(key);  
        for (Node x = st[i]; x != null; x = x.next;)  
            if (key.equals(x.key)) {  
                x.val = val;  
                return;  
            }  
        st[i] = new Node(key, val, st[i]);  
    }  
}
```

Analysis of Separate Chaining

- ▶ Under uniform hashing assumption, if n keys to hash in a table with size m , the length of each chain is $\sim n/m$.
- ▶ **Consequence:** Number of **probes** (calls to either `equals()` or `hashCode()`) for search/insert is proportional to n/m (m times faster than sequential search in a single chain).
 - ▶ m too large \rightarrow too many empty chains.
 - ▶ m too small \rightarrow chains too long.
 - ▶ Typical choice: $m \sim 1/4n$ \rightarrow constant time per operation.

Resizing in a separate-chaining hash table

- ▶ **Goal:** Average length of chain $n/m = \text{constant}$ lookup.
- ▶ Double hash table size when $n/m \geq 8$.
- ▶ Halve hash table size when $n/m \leq 2$.
- ▶ Need to rehash all keys when resizing (hashCode value for key does not change, but hash value changes as it depends on table size).

Parting thoughts about separate-chaining

- ▶ **Deletion:** Easy! Hash key, find its chain, search for a node that contains it and remove it.
- ▶ **Ordered operations:** not supported. Instead, look into (balanced) BSTs.
- ▶ Fastest and most widely used dictionary implementation for applications where key order is not important.

Lecture 20-21: Hash tables

- ▶ Hash functions
- ▶ Separate chaining
- ▶ Open addressing

Linear Probing

- ▶ Belongs in the open addressing family.
- ▶ Alternate approach to handle collisions when $m > n$.
- ▶ Maintain keys and values in two parallel arrays.
- ▶ When a new key collides, find next empty slot and put it there.
- ▶ If the array is full, the search would not terminate.

Linear Probing

- ▶ **Hash**: Map key to integer i between 0 and $m - 1$.
- ▶ **Insert**: Put at index i if free. If not, try $i + 1, i + 2$, etc.
- ▶ **Search**: Search table index i . If occupied but no match, try $i + 1, i + 2$, etc
 - ▶ If you find a gap then you know that it does not exist.
- ▶ Table size m **must** be greater than the number of key-value pairs n .

3.4 LINEAR PROBING DEMO



<http://algs4.cs.princeton.edu>

Linear Probing Example

key	hash	value	0	1	2	3	4	5	6	7	8	9	10	11	12	13	14	15
S	6	0							S									
E	10	1							S				E					
A	4	2					A		S				E					
R	14	3					A		S				E				R	
C	5	4					A	C	S				E				R	
H	4	5					A	C	S	H			E				R	
E	10	6					A	C	S	H			E				R	
X	15	7					A	C	S	H			E				R	X
A	4	8					A	C	S	H			E				R	X
M	1	9	M				A	C	S	H			E				R	X
P	14	10	P	M			A	C	S	H			E				R	X
L	6	11	P	M			A	C	S	H	L		E				R	X
E	10	12	P	M			A	C	S	H	L		E				R	X

entries in red are new
entries in gray are untouched
keys in black are probes
probe sequence wraps to 0
 ← keys[]
 ← vals[]

Trace of linear-probing ST implementation for standard indexing client

Practice time

- ▶ Assume a dictionary implemented using hashing and linear probing for handling collisions.
- ▶ Let $m = 7$ be the hash table size.
- ▶ For simplicity, we will assume that keys are integers and that the hash value for each key k is calculated as $h(k) = k \% m$.
- ▶ Insert the key-value pairs $(47, 0)$, $(3, 1)$, $(28, 2)$, $(14, 3)$, $(9, 4)$, $(47, 5)$ and show the resulting dictionary.

Answer

Key	Hash	Value
47	5	0
3	3	1
28	0	2
14	0	3
9	2	4
47	5	5

Keys	28	14	9	3		47	
Values	2	3	4	1		5	
Indices	0	1	2	3	4	5	6

Dictionary with linear probing implementation

```
public class LinearProbingHashST<Key, Value> {  
  
    private int m = 32768; // hash table size  
    private Value[] Vals = (Value[]) new Object[m];  
    private Key[] keys = (Key[]) new Object[m];  
  
    public Value get(Key key) {  
        for (int i = hash(key); keys[i] != null; i = (i+1) % m;)  
            if (key.equals(keys[i])) return vals[i];  
        return null;  
    }  
  
    public void put(Key key, Value val) {  
        int i;  
        for (int i = hash(key); keys[i] != null; i = (i+1) % m;)  
            if (key.equals(keys[i])){  
                break;  
            }  
        keys[i] = key;  
        vals[i] = val;  
    }  
}
```

Primary clustering

- ▶ **Cluster**: a contiguous block of keys.
- ▶ **Observation**: new keys likely to hash in middle of big clusters.

Analysis of Linear Probing

- ▶ **Proposition:** Under uniform hashing assumption, the average number of probes in a linear-probing hash table of size m that contains $n = \alpha m$ keys is at most
 - ▶ $1/2(1 + \frac{1}{1 - \alpha})$ for search hits and
 - ▶ $1/2(1 + \frac{1}{(1 - \alpha)^2})$ for search misses and insertions.
 - ▶ [Knuth 1963]
- ▶ **Parameters:**
 - ▶ m too large -> too many empty array entries.
 - ▶ m too small -> search time becomes too long.
 - ▶ Typical choice for **load factor**: $\alpha = n/m \sim 1/2$ -> constant time per operation.

Resizing in a linear probing hash table

- ▶ **Goal:** Fullness of array (load factor) $n/m \leq 1/2$.
- ▶ Double hash table size when $n/m \geq 1/2$.
- ▶ Halve hash table size when $n/m \leq 1/8$.
- ▶ Need to rehash all keys when resizing (hash code does not change, but hash value changes as it depends on table size).
- ▶ Deletion not straightforward.

Quadratic Probing

- ▶ Another open addressing technique that aims to reduce primary clustering by taking the original hash index and adding successive values of an arbitrary quadratic polynomial until an open slot is found.
- ▶ Modify the probe sequence so that $h(k, i) = (h(k) + c_1i + c_2i^2) \% m$, $c_2 \neq 0$, where i is the i -th time we have had a collision for the given index.
 - ▶ When $c_2 = 0$, then quadratic probing degrades to linear probing.

Quadratic probing - Example

- ▶ $h(k) = k \% m$ and $h(k, i) = (h(k) + i^2) \% m$.
- ▶ Assume $m = 13$, and key-value pairs to insert: $(17,0)$, $(33,1)$, $(18,2)$, $(20,3)$, $(44,4)$, $(11,5)$, $(19,6)$, $(7,7)$.

	0	1	2	3	4	5	6	7	8	9	10	11	12	
$(17,0)$					17									
$(33,1)$					17			33						
$(18,2)$					17	18		33						
$(20,3)$					17	18		33	20					Collision!
$(44,4)$					17	18	44	33	20					Collision!
$(11,5)$					17	18	44	33	20			11		
$(19,6)$					17	18	44	33	20		19	11		Collision!
$(7,7)$				7	17	18	44	33	20		19	11		Collision!

PRACTICE TIME

- ▶ $h(k) = k \% m$ and $h(k, i) = (h(k) + i^2) \% m$.
- ▶ Assume $m = 9$, and key-value pairs to insert: $(3,0)$, $(9,1)$, $(18,2)$, $(0,3)$, $(4,4)$, $(36,5)$.

ANSWER

- ▶ $h(k) = k \% m$ and $h(k, i) = (h(k) + i^2) \% m$.
- ▶ Assume $m = 9$, and key-value pairs to insert: $(3,0)$, $(9,1)$, $(18,2)$, $(0,3)$, $(4,4)$, $(36,5)$.

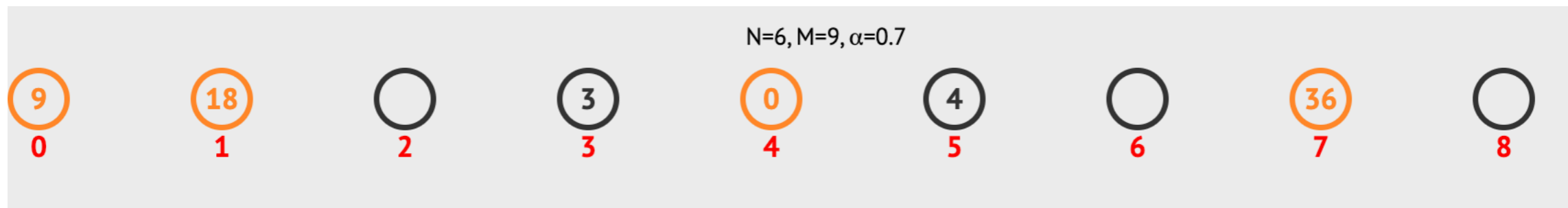

Summary for dictionary operations

	Worst case			Average case		
	Search	Insert	Delete	Search	Insert	Delete
BST	n	n	n	$\log n$	$\log n$	\sqrt{n}
balanced BST	$\log n$	$\log n$	$\log n$	$\log n$	$\log n$	$\log n$
Separate chaining	n	n	n	1	1	1
Open addressing	n	n	n	1	1	1

Hash tables vs balanced search trees

▶ Hash tables:

- ▶ Simpler to code.
- ▶ No effective alternative of unordered keys.
- ▶ Faster for simple keys (a few arithmetic operations versus $\log n$ compares).

▶ Balanced search trees:

- ▶ Stronger performance guarantee.
- ▶ Support for ordered dictionary operations.
- ▶ Easier to implement `compareTo()` than `hashCode()`.

▶ Java includes both:

- ▶ Balanced search trees: `java.util.TreeMap`, `java.util.TreeSet`.
- ▶ Hash tables: `java.util.HashMap`, `java.util.IdentityHashMap`.

Lecture 20-21: Hash tables

- ▶ Hash functions
- ▶ Separate chaining
- ▶ Open addressing

Readings:

- ▶ Recommended Textbook: Chapter 3.4 (Pages 458-477)
- ▶ Website:
 - ▶ <https://algs4.cs.princeton.edu/34hash/>
- ▶ Visualization:
 - ▶ <https://visualgo.net/en/hashtable>

Problem 1

- ▶ Insert the keys E, A, S, Y, Q, U, T, I, O, N in that order into an initially empty table of $m=5$ lists, using separate chaining. Use the hash function $11 * k \% m$ to transform the k -th letter of the English alphabet into a table index.

ANSWER 1

- ▶ Insert the keys E, A, S, Y, Q, U, T, I, O, N in that order into an initially empty table of $m=5$ lists, using separate chaining. Use the hash function $11*k\%m$ to transform the k -th letter of the English alphabet into a table index.
- ▶ 0 -> E -> Y -> T -> O
- ▶ 1 -> A -> U
- ▶ 2 -> Q
- ▶ 3 -> null
- ▶ 4 -> S -> I -> N