

Lecture 18: Virtual Memory

CS 105

Spring 2026

Multiprocessing: The Illusion

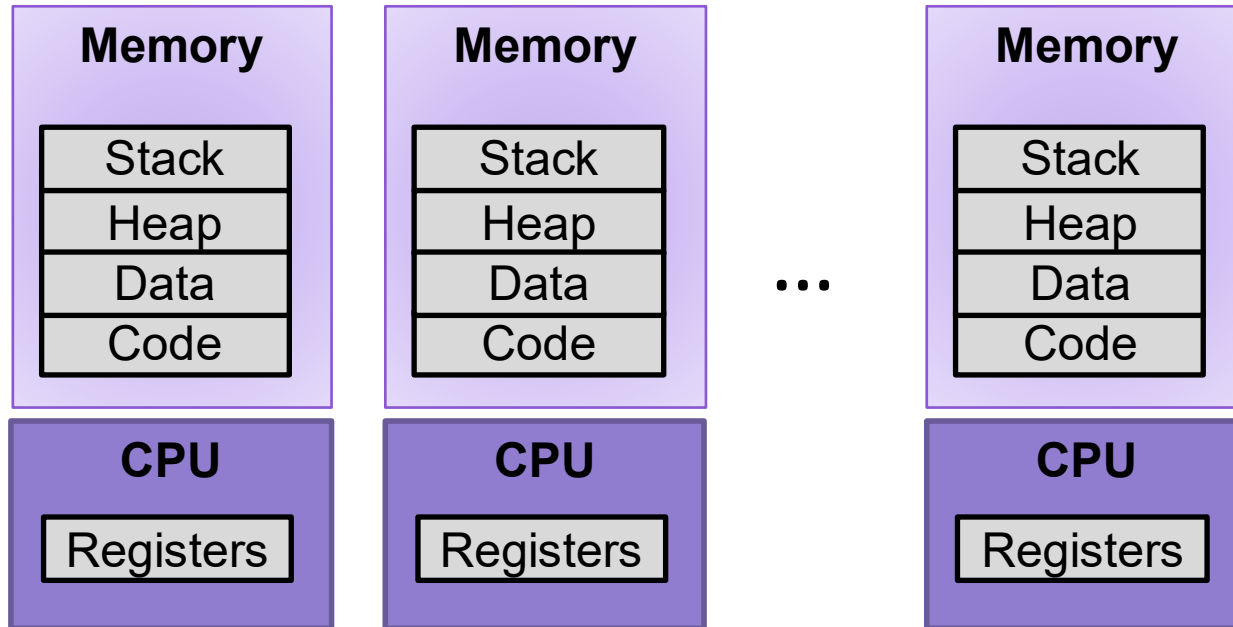

- Process provides each program with two key abstractions:
 - **Logical control flow**
 - Each program seems to have exclusive use of the CPU
 - Provided by kernel mechanism called **context switching**
 - **Private address space**
 - Each program seems to have exclusive use of main memory.
 - Provided by kernel mechanism called **virtual memory**

Multiprocessing: The Reality

- Computer runs many processes simultaneously
- Running program “top” on Mac
 - System has 547 processes, 5 of which are active
 - Identified by Process ID (PID)



Virtual Memory Goals

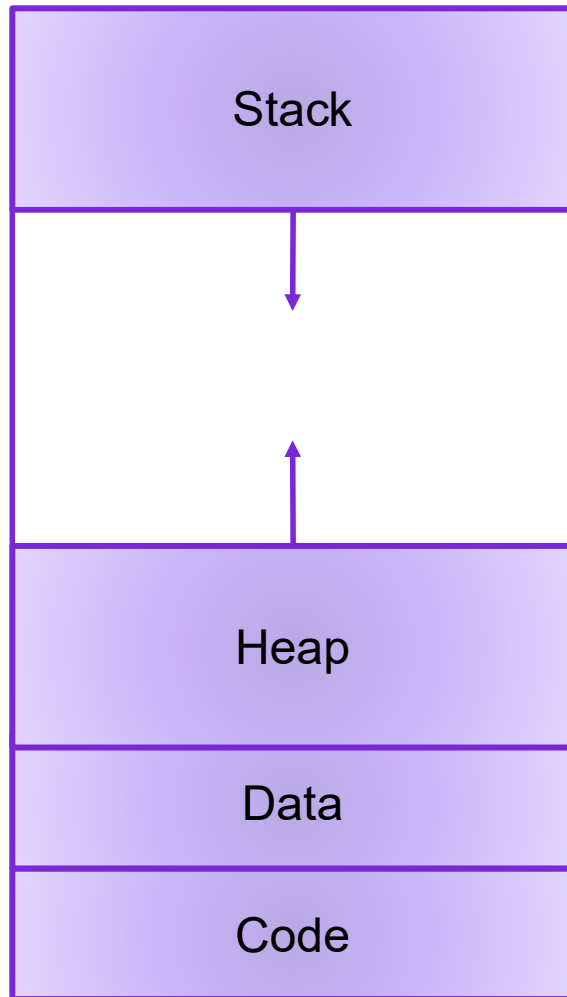

- **Isolation:** don't want different process states collided in physical memory
- **Efficiency:** want fast reads/writes to memory
- **Sharing:** want option to overlap for communication
- **Utilization:** want best use of limited resource
- **Virtualization:** want to create illusion of more resources

Address Translation

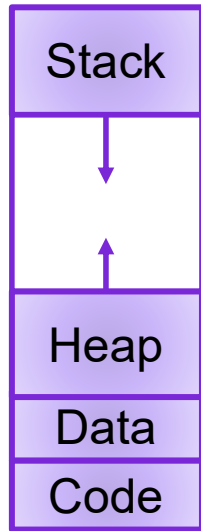

Virtual Address



invalid

Exception

Physical Address

Data

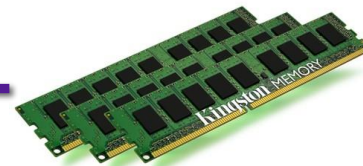

Base-and-Bound

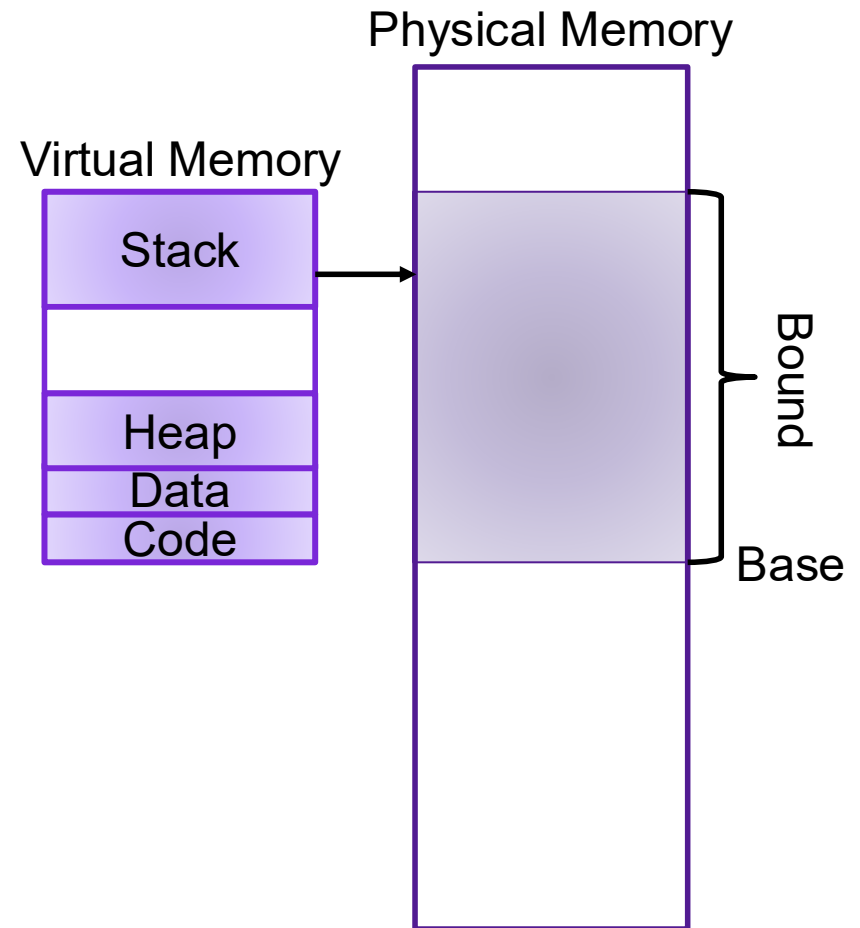

Base-and-Bound

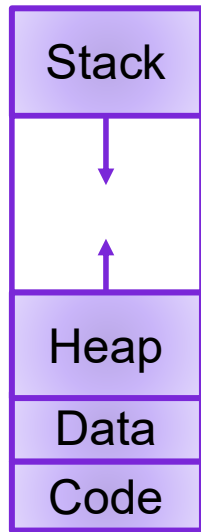

vaddr

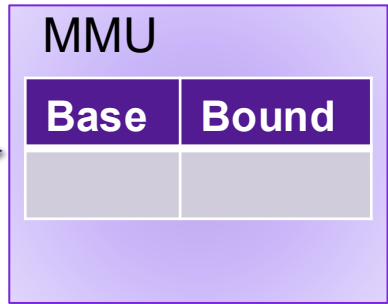

vaddr > Bound

Exception

$$paddr = vaddr + Base$$

Data

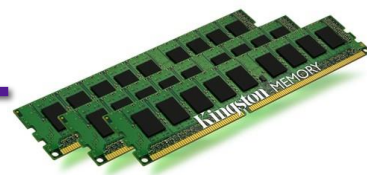

Exercise 1: Base-and-Bound

Assume that you are currently executing a process P with Base 0x1234 and Bound 0x100.

- What is the physical address that corresponds to the virtual address 0x47?
- What is the physical address that corresponds to the virtual address 0x123?

Evaluating Base-and-Bound



- **Isolation:** don't want different process states collided in physical memory
- **Efficiency:** want fast reads/writes to memory
- **Sharing:** want option to overlap for communication
- **Utilization:** want best use of limited resource
- **Virtualization:** want to create illusion of more resources



Segmentation

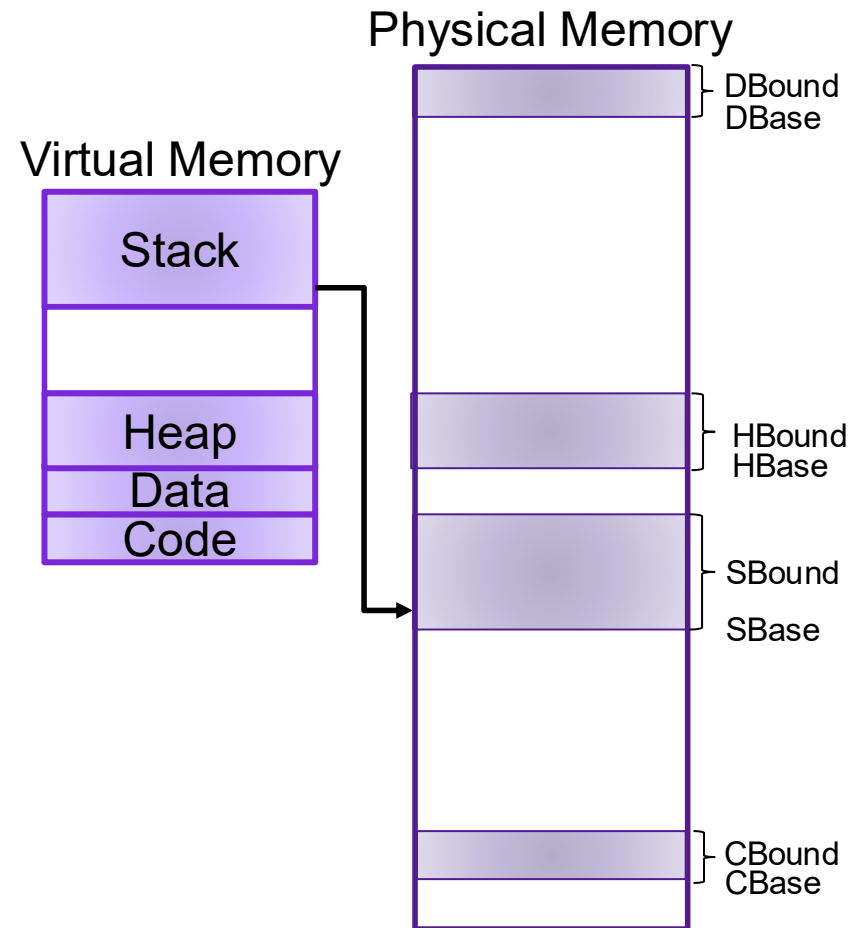

Segmentation

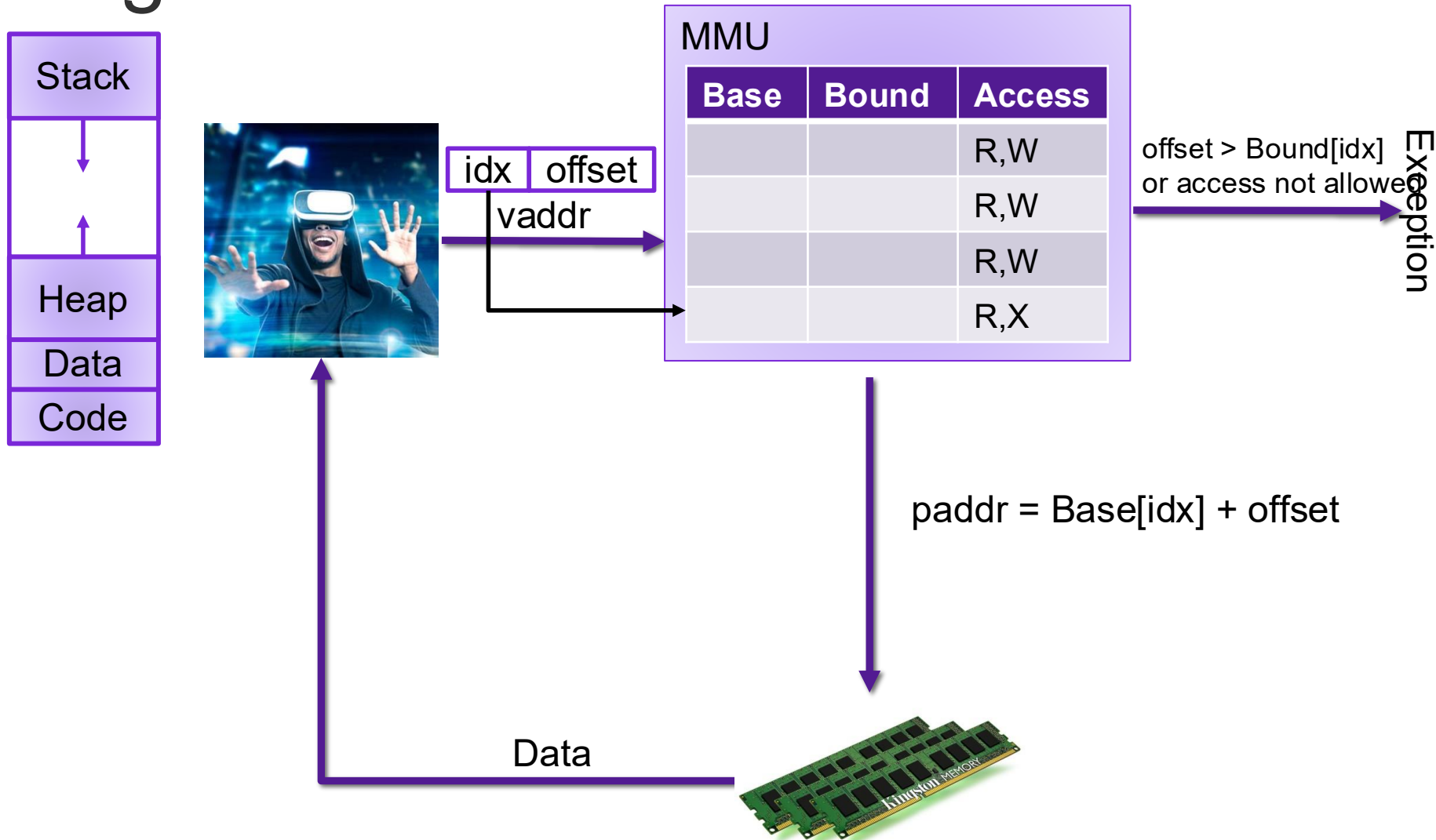

Exercise 2: Segmentation

Assume that you are currently executing a process P with the following segment table:

Base	Bound	Access
0x4747	0x80	R,W
0x2424	0x40	R,W
0x0023	0x80	R,W
0x1000	0x200	R,X

- What is the physical address that corresponds to the virtual address 0x001?
- What is the physical address that corresponds to the virtual address 0xD47?

Evaluating Segmentation



- **Isolation:** don't want different process states collided in physical memory
- **Efficiency:** want fast reads/writes to memory
- **Sharing:** want option to overlap for communication
- **Utilization:** want best use of limited resource
- **Virtualization:** want to create illusion of more resources



Paging

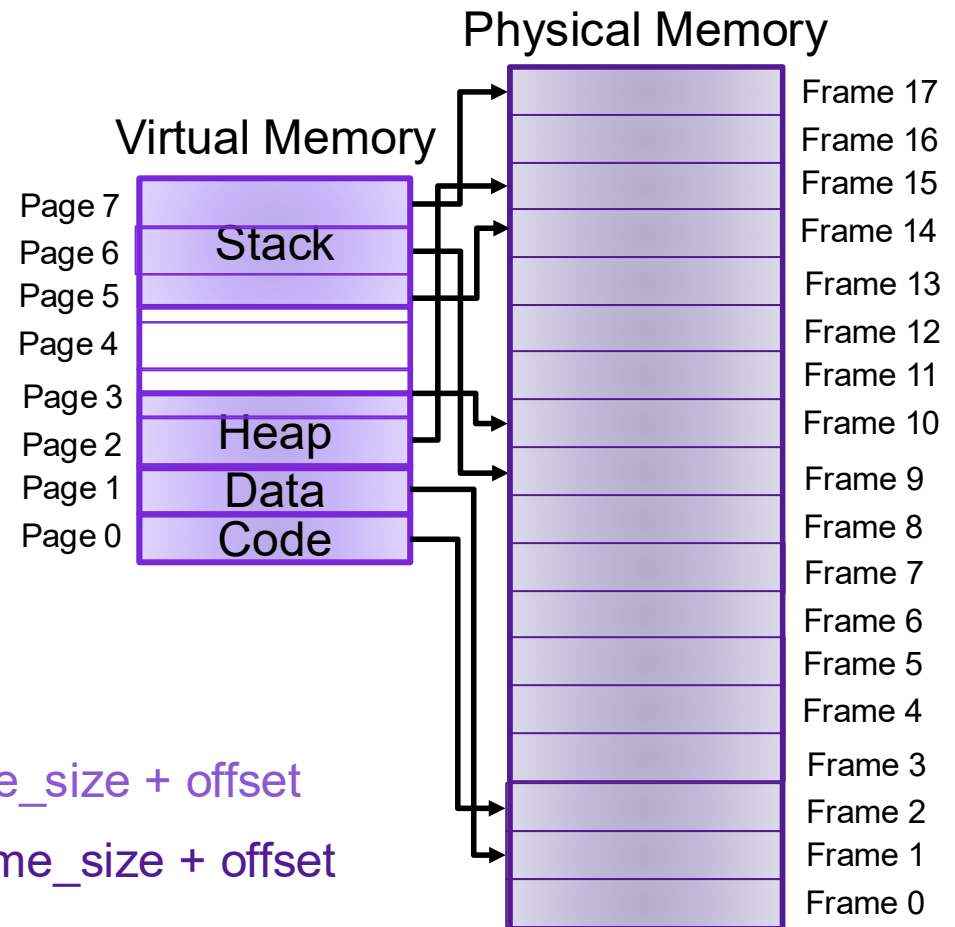

$vaddr = page_num * page_size + offset$

$paddr = frame_num * frame_size + offset$

Paging

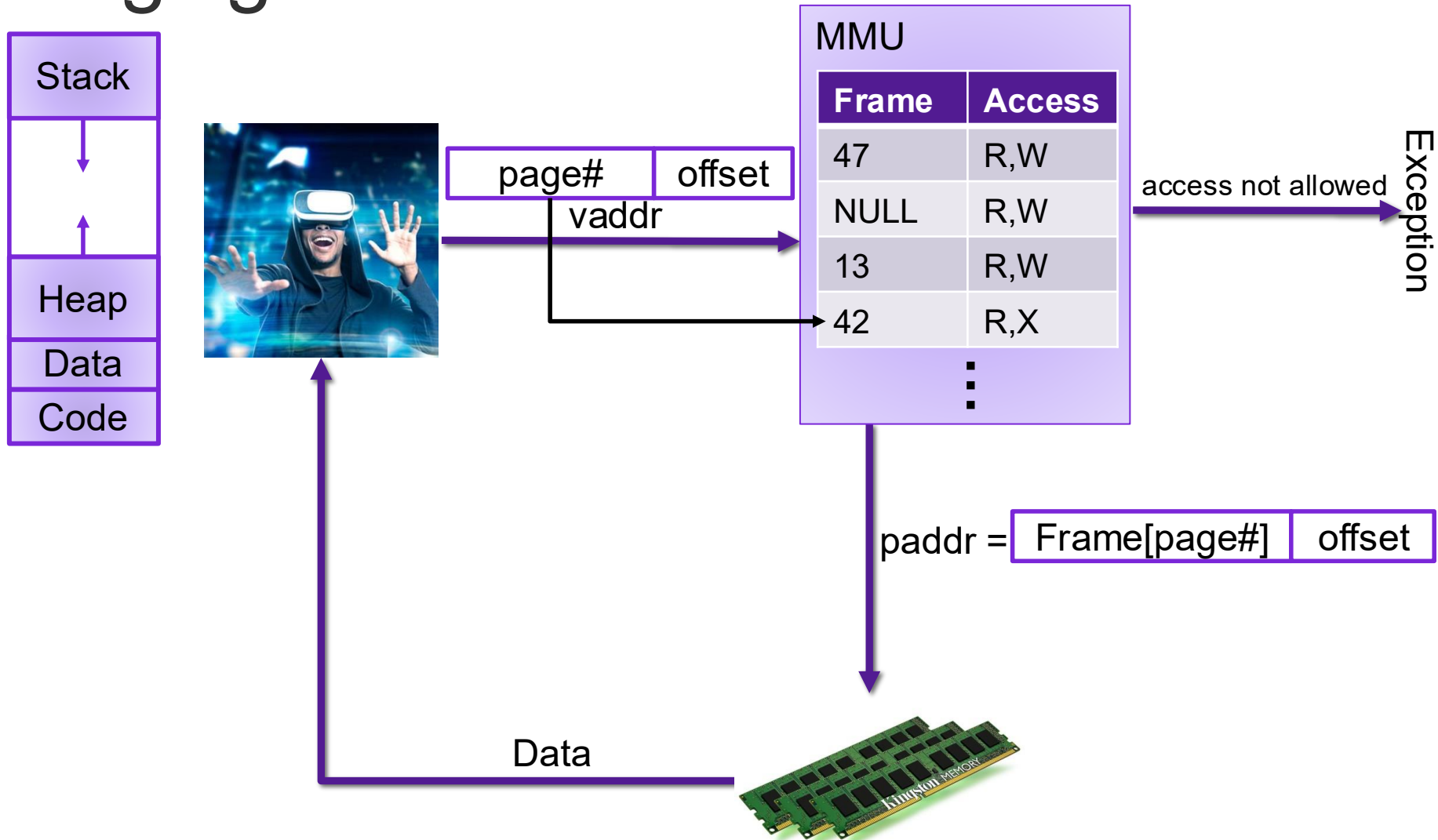

Exercise 3: Paging

Assume that you are currently executing a process P with the following page table on a system with 16 byte pages:

	Frame	Access
⋮		
0x17	0x47	R,W
0x16	0xF4	R,W
0x15	NULL	R,W
0x14	0x23	R,X
⋮		

- What is the physical address that corresponds to the virtual address 0x147?
- What is the physical address that corresponds to the virtual address 0x16E?

Exercise 3: Paging

Assume that you are currently executing a process P with the following page table on a system with 16 byte pages:

	Frame	Access
⋮		
0x17	0x47	R,W
0x16	0xF4	R,W
0x15	NULL	R,W
0x14	0x23	R,X
⋮		

Memory as a Cache

- each page table entry has a valid bit
- for valid entries, frame indicates physical address of page in memory
- a **page fault** occurs when a program requests a page that is not currently in memory
 - handled much like a cache miss
 - evict another page in memory to make space (which one?)
 - takes time to handle, so context switch

MMU		
v	Frame	Access
1	0x47	R,W
0	NULL	R,W
0	0x13	R,W
1	0xF1	R,X
	⋮	

Memory as a Cache

Assume that you are currently executing a process P with the following page table on a system with 16 byte pages:

	v	Frame	Access
⋮			
0x17	1	0x47	R,W
0x16	0	NULL	R,W
0x15	0	0x13	R,W
0x14	1	0xF1	R,X
⋮			

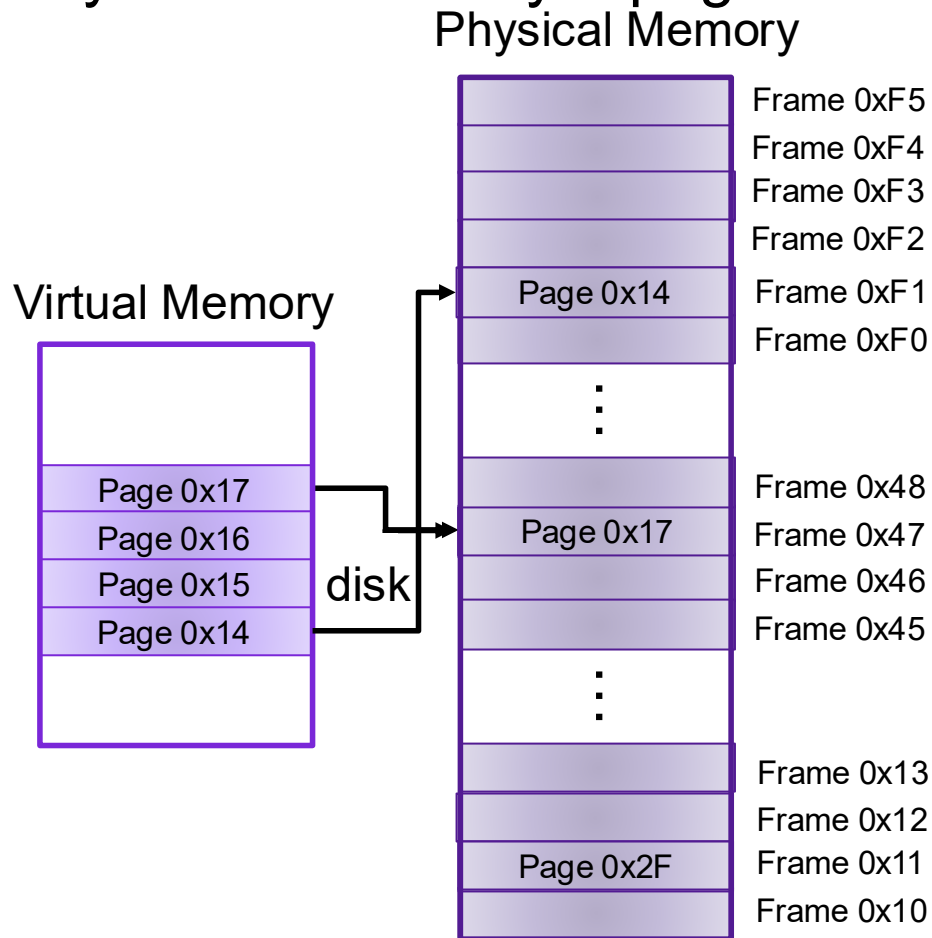

Thrashing

- working set is the collection of a pages a process requires in a given time interval
- if it doesn't fit in memory, program will thrash

Exercise 4: Paging

Assume that you are currently executing a process P with the following page table on a system with 256 byte pages:

	v	Frame	Access
⋮			
0xFA	1	0x47	R,W
0xF9	1	0x24	R,W
0xF8	0	NULL	R,W
0xF7	0	0x23	R,X
⋮			

- What is the physical address that corresponds to the virtual address 0xF947?
- What is the physical address that corresponds to the virtual address 0xF700?
- What is the physical address that corresponds to the virtual address 0xF813?

Evaluating Paging



- **Isolation:** don't want different process states collided in physical memory
- **Efficiency:** want fast reads/writes to memory
- **Sharing:** want option to overlap for communication
- **Utilization:** want best use of limited resource
- **Virtualization:** want to create illusion of more resources

